

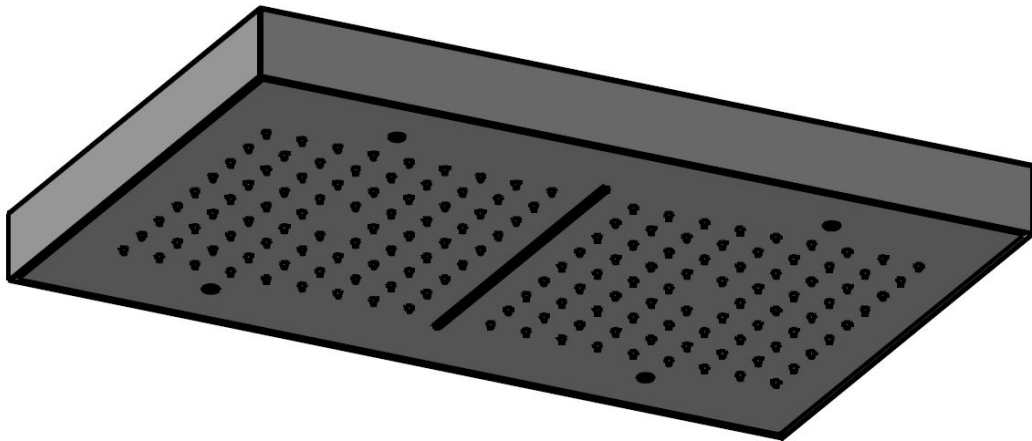

IT - ISTRUZIONI DI MONTAGGIO
EN - ASSEMBLY INSTRUCTIONS
DE - MONTAGEANLEITUNG
FR - INSTRUCTIONS DE MONTAGE

G26229C

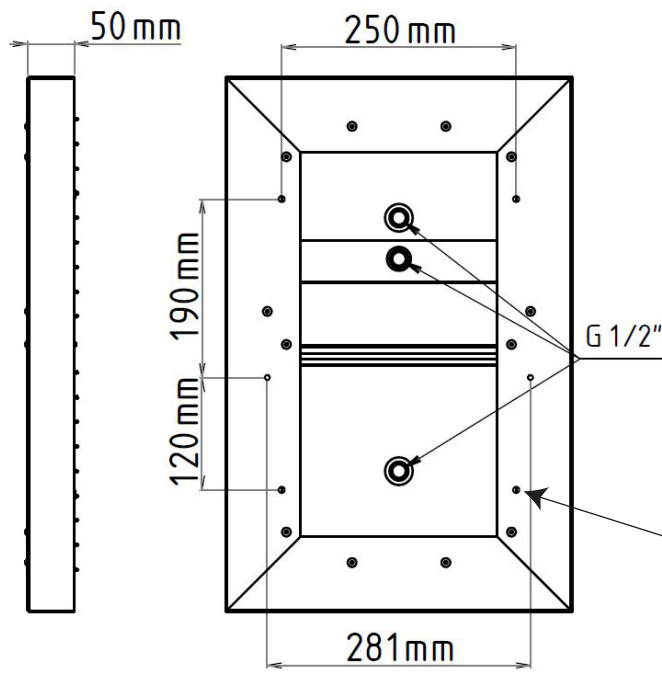

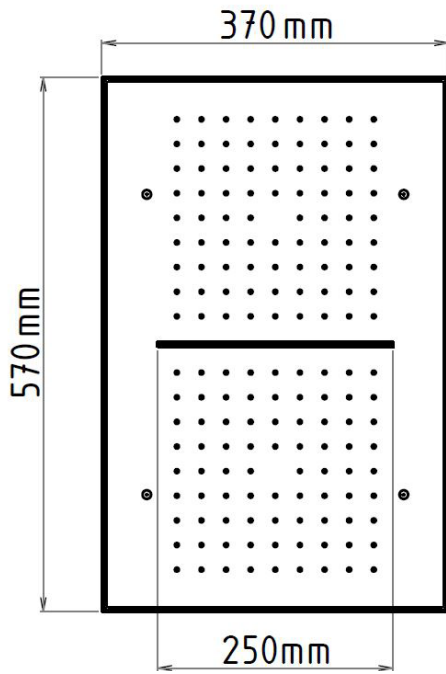

IT-Barra filettata
EN-Threaded rod
DE-Gewindestange
FR-Tige filetée



MAX 70°C
BEST 38/40°C



MIN 1 Bar
MAX 5 Bar
BEST 3 Bar

IT-Dimensioni foro
EN-Hole size
DE-Lochgröße
FR-Taille du trou

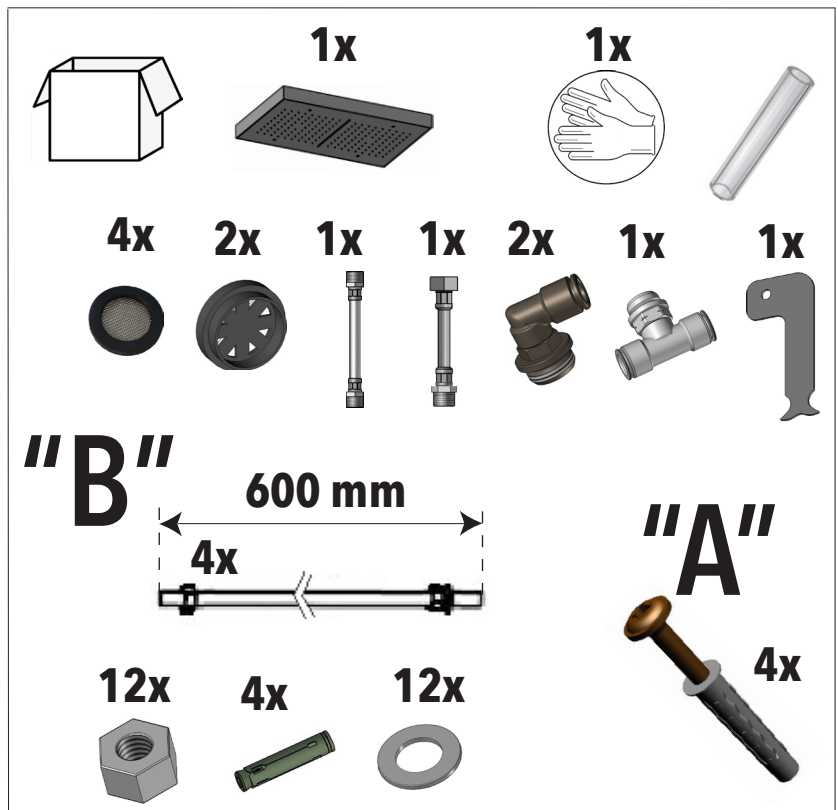
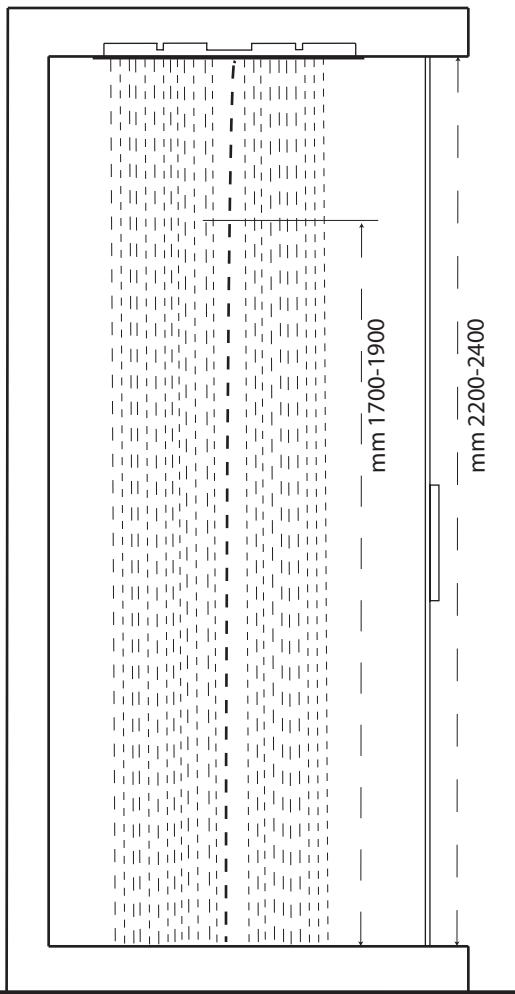
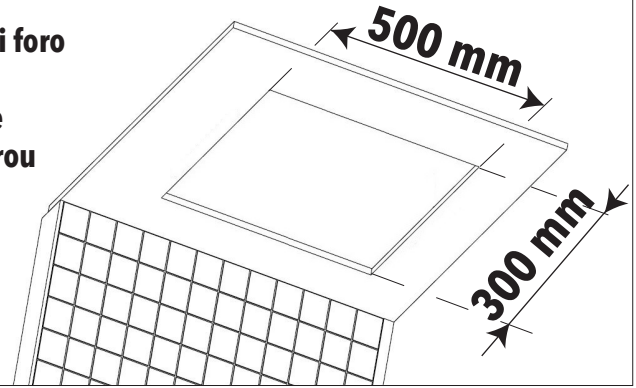

IT - L'apparechio deve essere installato da personale abilitato ai sensi e per l'effetto delle leggi in vigore.

EN - According to the law, all installation and maintenance operations require a qualified person.

DE - Das Gerät muss von qualifiziertem Personal gemäß den geltenden Gesetzen installiert werden.

FR - L'appareil doit être installé par du personnel qualifié conformément et pour l'effet des lois en vigueur.

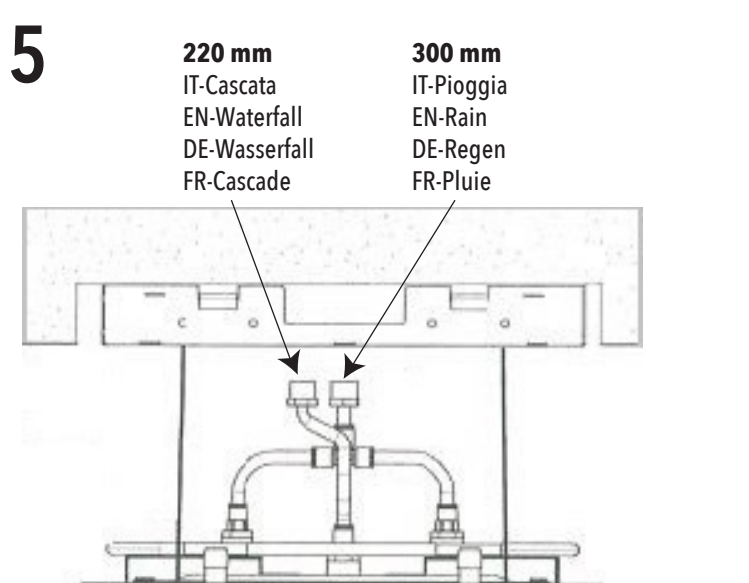
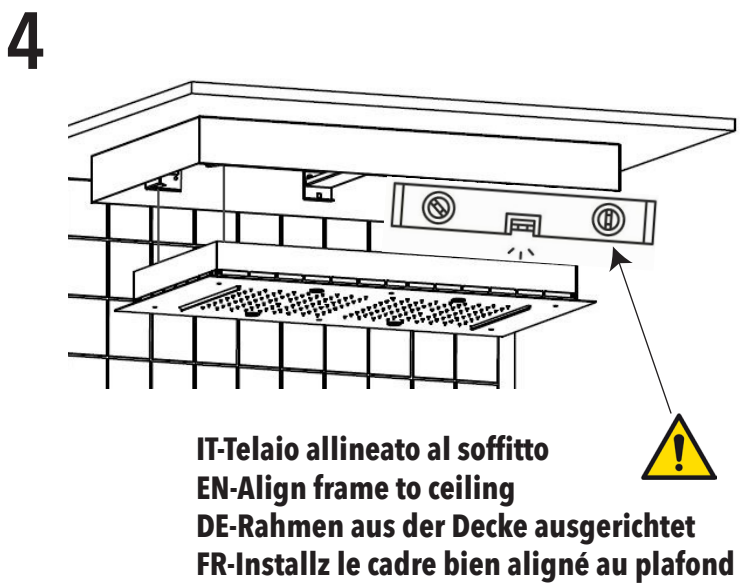
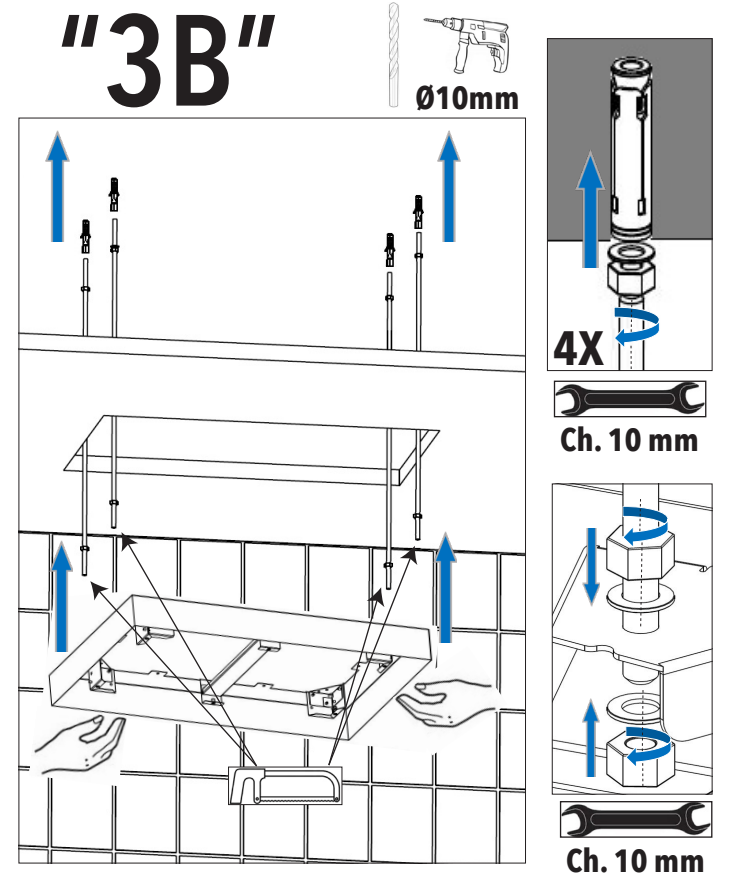
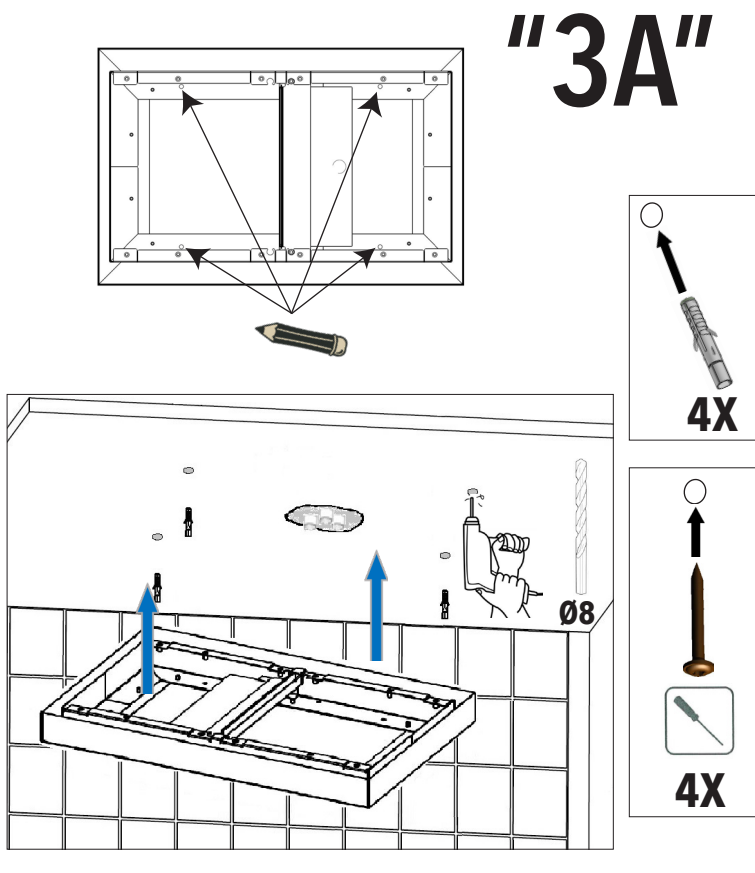
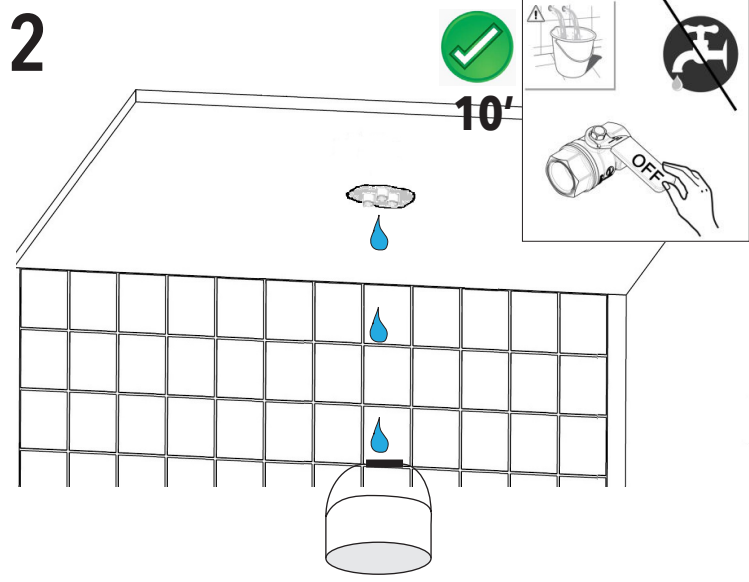
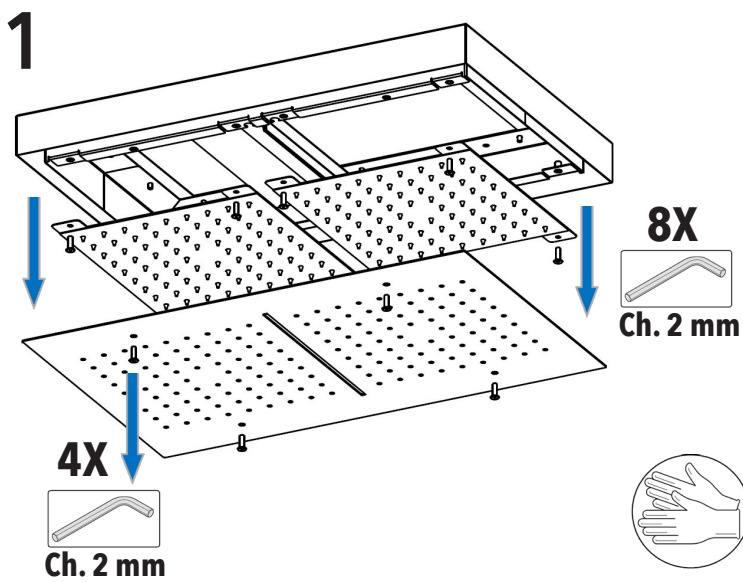

6

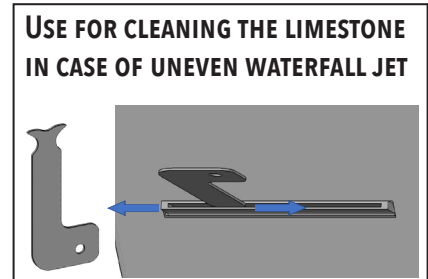
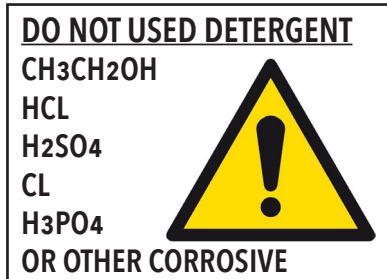
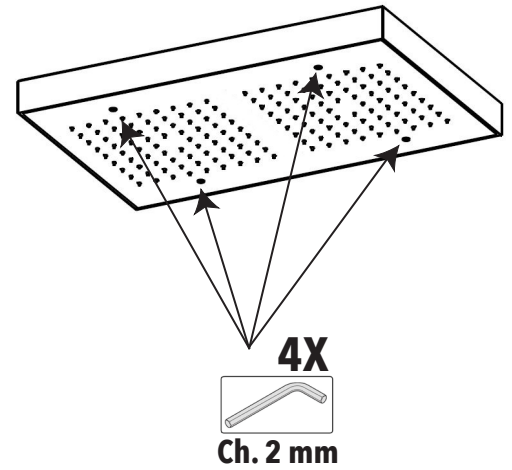
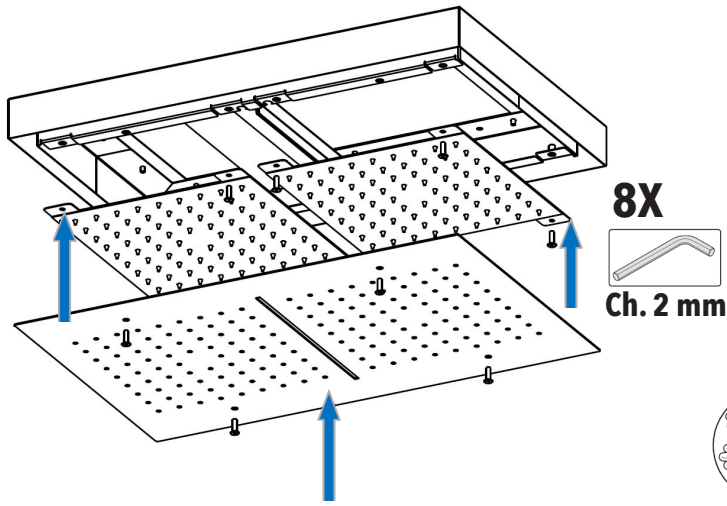

✗ IT - LA GARANZIA DEL PRODOTTO NON COPRE

L'utilizzo improprio.
 L'errata predisposizione dell'impianto idraulico.
 Danni causati da depositi di calcare o altre impurità.
 Detergenti non adatti.

EN - NOT COVERED BY PRODUCT CARE

Not correct use.
 Incorrect setup of the hydraulic system.
 Water impurities or limestone deposits.
 Improper detergents.

DE - DIE PRODUKTGARANTIE GILT NICHT

Die falsche Verwendung
 Die falsche Anordnung des Hydrauliksystems.
 Schäden durch Kalkablagerungen oder andere Verunreinigungen.
 Ungeeignete Reiniger.

FR - LA GARANTIE DU PRODUIT NE COUVRE PAS

Utilisation incorrecte.
 La mauvaise disposition du système hydraulique.
 Dommages causés par des dépôts de calcaire ou d'autres impuretés.
 Nettoyants inappropriés.

✓ IT - DUE ANNI DI GARANZIA DEL PRODOTTO

Contro i difetti o vizi di fabbricazione.

EN - TWO-YEAR PRODUCT CARE

Against defects of fabrication.

DE - ZWEI JAHRE LANG PRODUKTGARANTIE

Gegen Mängel oder Herstellungsfehler

FR - GARANTIE DE PRODUITS DE DEUX ANS

Contre les défauts de fabrication.

IT - ATTENZIONE: Si declina ogni responsabilità relativa ad eventuali inesattezze contenute in queste istruzioni dovute ad errori di trascrizione.

EN - WARNING: We decline all responsibility for eventual inaccuracy contained in the instructions due to transcript errors.

DE - ACHTUNG: Wir lehnen jede Verantwortung für Ungenauigkeiten in diesen Anleitung aufgrund von Transkriptionsfehlern ab.

FR - ATTENTION: Nous déclinons toute responsabilité pour toute inexactitude contenue dans ces instructions en raison d'erreurs de transcription.



Via Mattei, 14
 25060 Collebeato (BS) - Italy

Phone: +39 030 26 80 854
 Fax: +39 030 65 93 335
 Email: info@artisitaly.com