

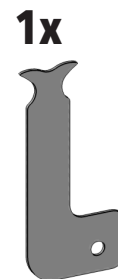

IT - ISTRUZIONI DI MONTAGGIO
EN - ASSEMBLY INSTRUCTIONS
DE - MONTAGEANLEITUNG
FR - INSTRUCTIONS DE MONTAGE

G26146C

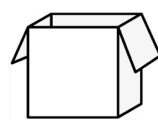

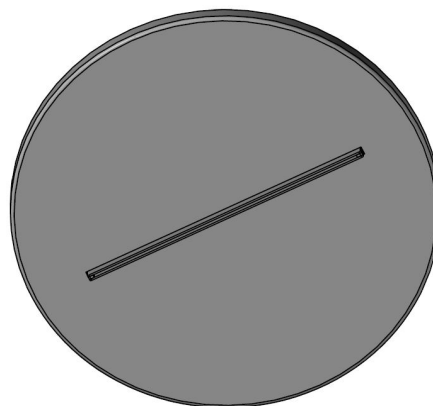
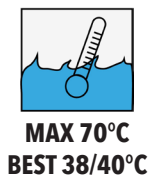
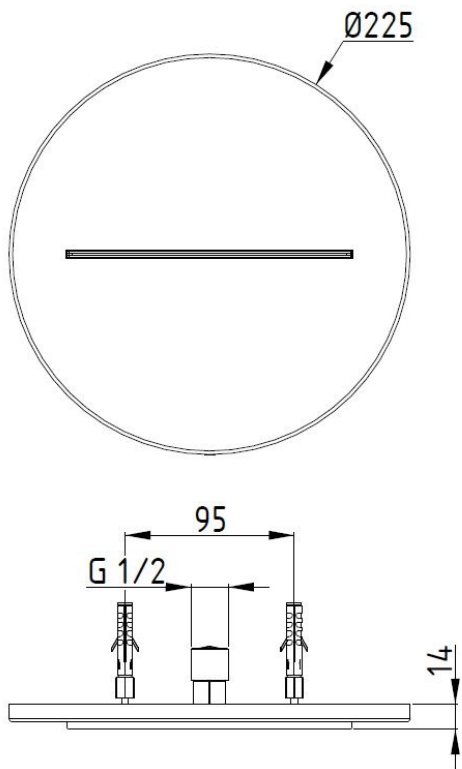

1x

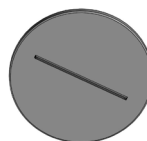

1x

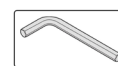

1x



1

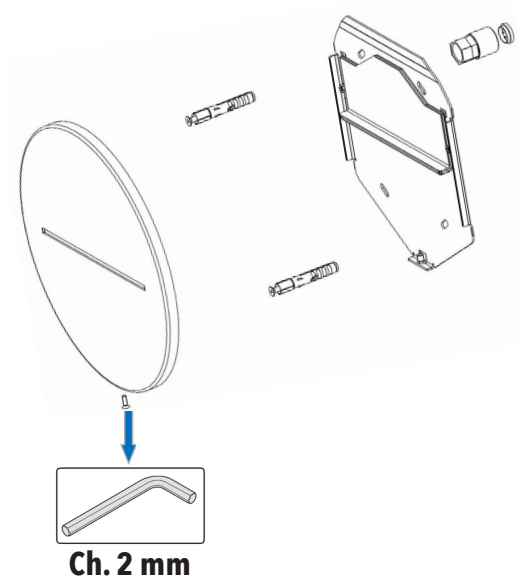

2

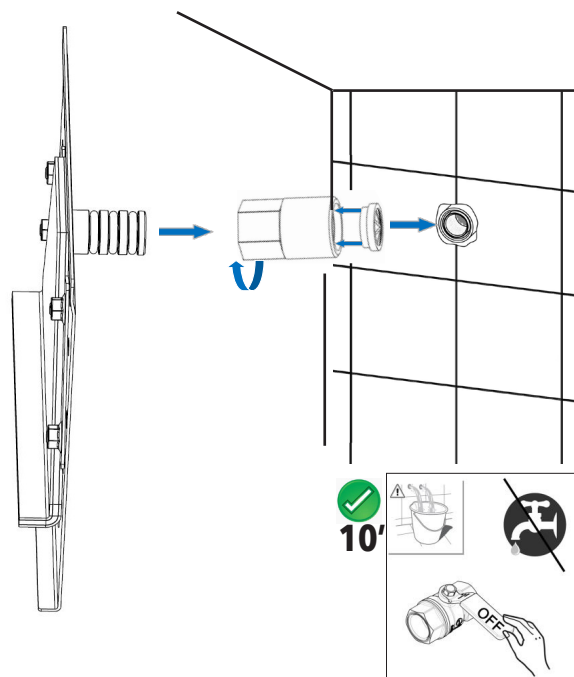

! IT - L'apparecchio deve essere installato da personale abilitato ai sensi e per l'effetto delle leggi in vigore.
 EN - According to the law, all installation and maintenance operations require a qualified person.
 DE - Das Gerät muss von qualifiziertem Personal gemäß den geltenden Gesetzen installiert werden.
 FR - L'appareil doit être installé par du personnel qualifié conformément et pour l'effet des lois en vigueur.

3

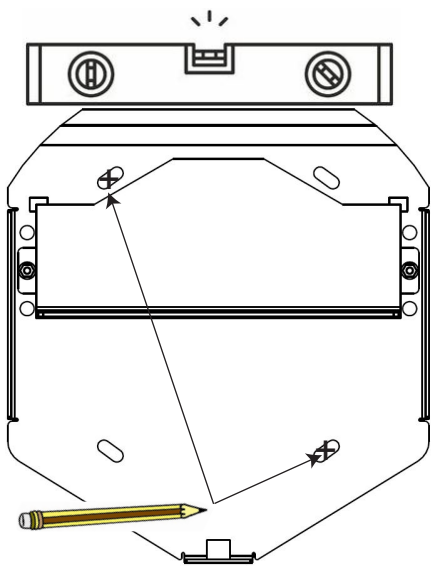

4

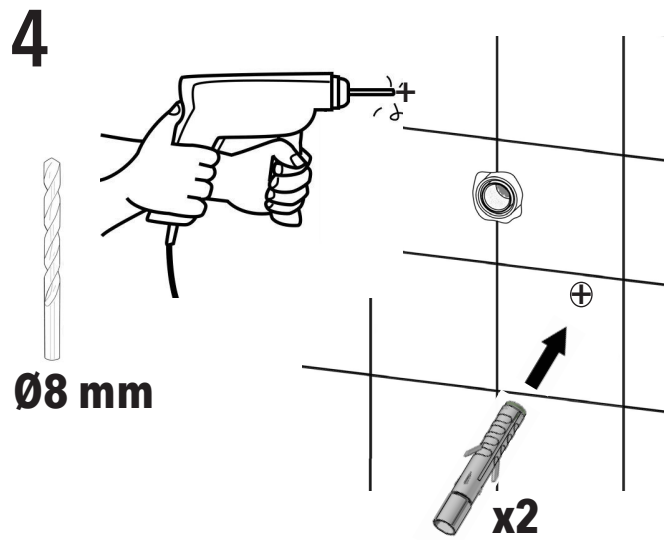

5



IT-Tubo filettato.
EN-Threaded tube.
DE-Gewinderohr.
FR-Tube fileté.

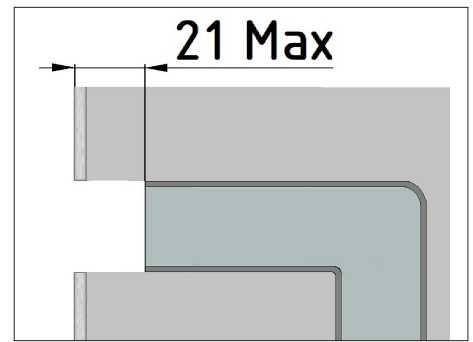
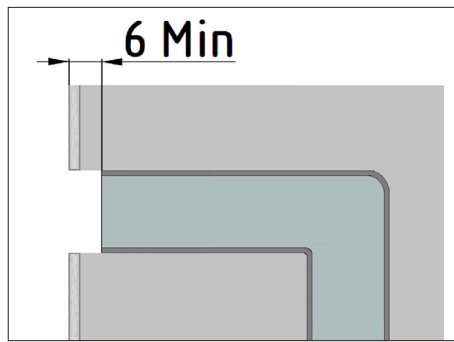
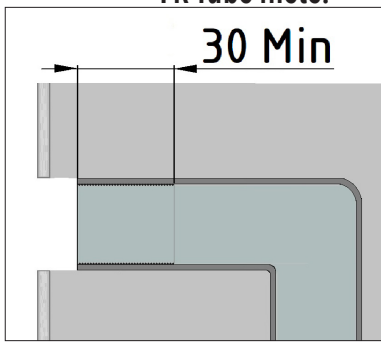

IT-Boccola allineata alla parete.
EN-Fitting aligned to the wall.
DE-Durchführung an der Wand ausgerichtet.
FR-Bague alignée avec le mur.

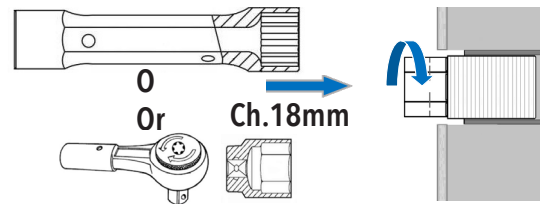
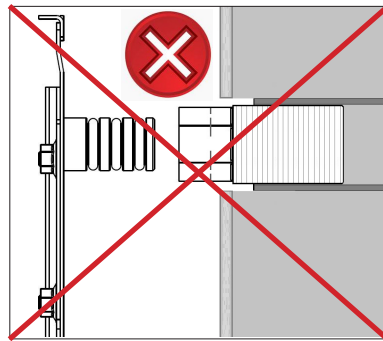
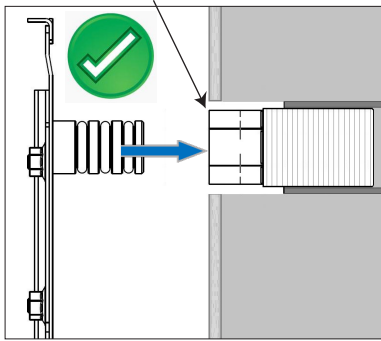

IT-Smusso imbocco, Superficie priva di bave.
EN-Chamfer inlet, surface free of burrs.
DE-Fase, gratfreie Oberfläche.
FR-Chanfrein, surface sans bavure.

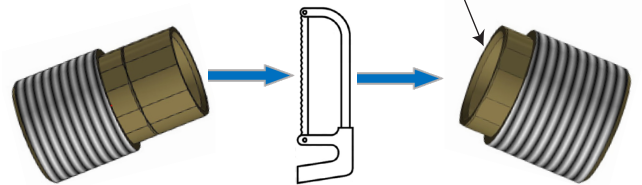

IT-Boccola e innesto tagliabili.
EN-Bushing and graft can be cut.
DE-Buchse und Kupplung können geschnitten werden.
FR-La douille et l'accouplement peuvent être coupés.

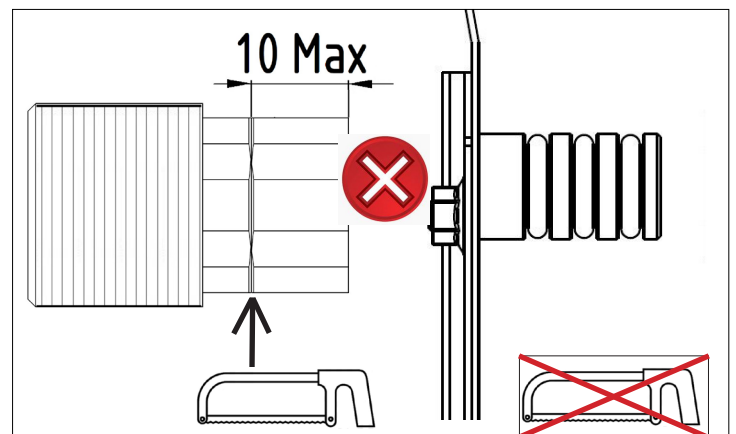
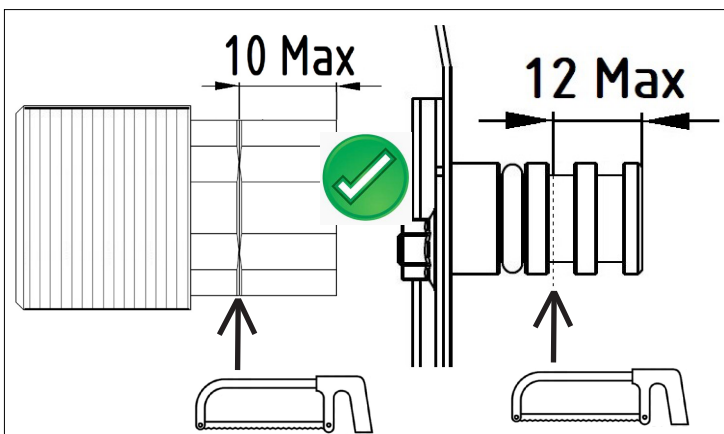

6

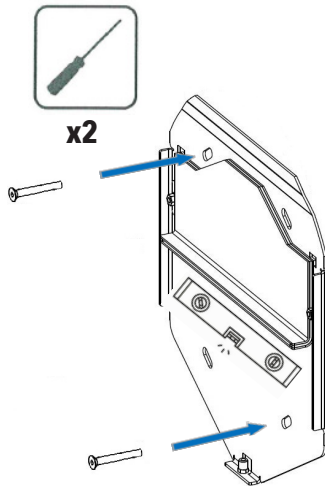

7

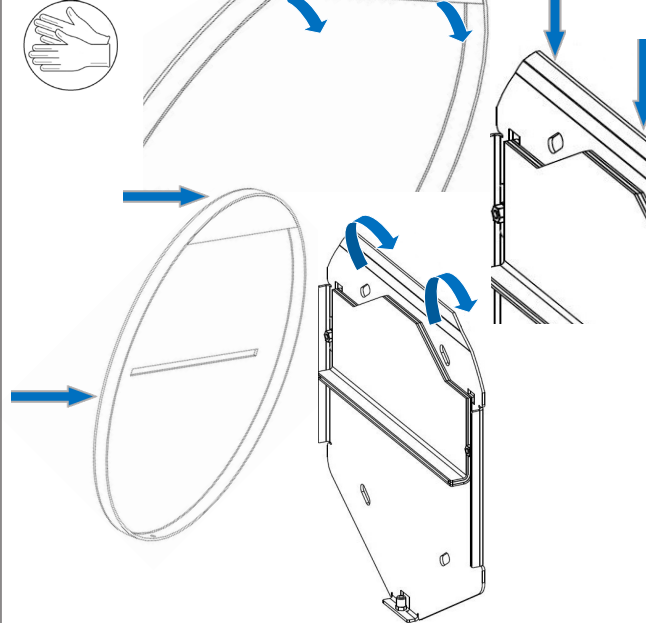

8

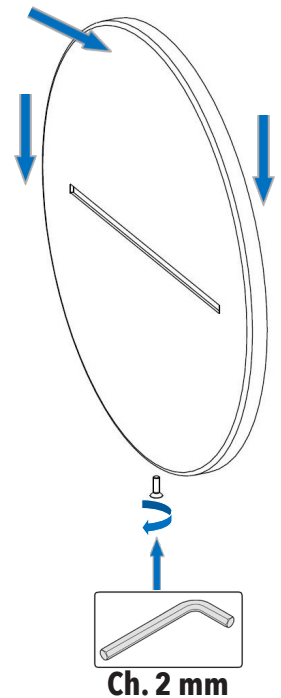

DO NOT USED DETERGENT

CH₃CH₂OH
HCL
H₂SO₄
CL
H₃PO₄
OR OTHER CORROSIVE



**USE FOR CLEANING THE LIMESTONE
IN CASE OF UNEVEN WATERFALL JET**

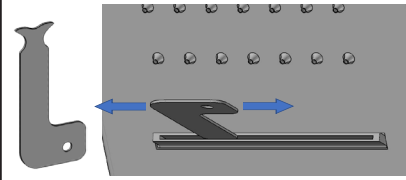

IT - LA GARANZIA DEL PRODOTTO NON COPRE

L'utilizzo improprio.
L'errata predisposizione dell'impianto idraulico.
Danni causati da depositi di calcare o altre impurità.
Detergenti non adatti.

EN - NOT COVERED BY PRODUCT CARE

Not correct use.
Incorrect setup of the hydraulic system.
Water impurities or limeston.
Not suitable detergents.

DE - DIE PRODUKTGARANTIE DECKT NICHT AB

Fehlerhafte Verwendung.
Die falsche Anordnung des Hydrauliksystems.
Schäden durch Kalkablagerungen oder andere
Verunreinigungen.
Ungeeignete Reiniger.

FR - LA GARANTIE DU PRODUIT NE COUVRE PAS

Utilisation incorrecte.
La mauvaise disposition du système hydraulique.
Dommages causés par des dépôts de calcaire ou
d'autres impuretés.
Nettoyants inappropriés.



IT - DUE ANNI DI GARANZIA DEL PRODOTTO

Contro i difetti o vizi di fabbricazione.

EN - TWO-YEAR PRODUCT CARE

Against defects or defects of fabrication.

DE - ZWEI JAHRE PRODUKTGARANTIE

Gegen Mängel oder Herstellungsfehler

FR - GARANTIE DE PRODUITS DE DEUX ANS

Contre les défauts de fabrication ou les défauts.

IT - ATTENZIONE: Si declina ogni responsabilità relativa ad eventuali inesattezze contenute in queste istruzioni dovute ad errori di trascrizione.

EN - WARNING: We decline all responsibility for eventual inaccuracy contained in the instructions due to transcript errors.

DE - ACHTUNG: Wir lehnen jede Verantwortung für Ungenauigkeiten in diesen Anleitung aufgrund von Transkriptionsfehlern ab.

FR - ATTENTION: Nous déclinons toute responsabilité pour toute inexactitude contenue dans ces instructions en raison d'erreurs de transcription.